

Assembly guide

A3V2 Unit



WELCOME ABOARD !

Let's assemble Your dream furniture and get you on the road

LET'S GO!

The versions

Nota Bene : our furniture comes in several versions depending on the vehicle model. These instructions are based on an adaptable version of the furniture. The shape of some parts (particularly at the rear of the furniture) may vary, but the assembly principle and part names remain the same.

A3.1 V2 ADAPTABLE



A3.2 V2 T5/T6



A3.3 V2 TRAFIC



A3.4 V2 EXPERT/JUMPY



SHOW OFF YOUR SKILLS & INSPIRE THE VANLIFE
COMMUNITY!

Share your build on Facebook, Instagram ou TikTok
#SimpleVansLife :

Best content wins awesome prizes.



Material required for assembly:

- Masking tape
- Square (optional)
- PZ1 & PZ2 screwdriver
- Wood glue (slow-drying recommended)
- Damp cloth (or paper towel)
- Putty knife or ruler (optional)
- Pencil

Package contents :

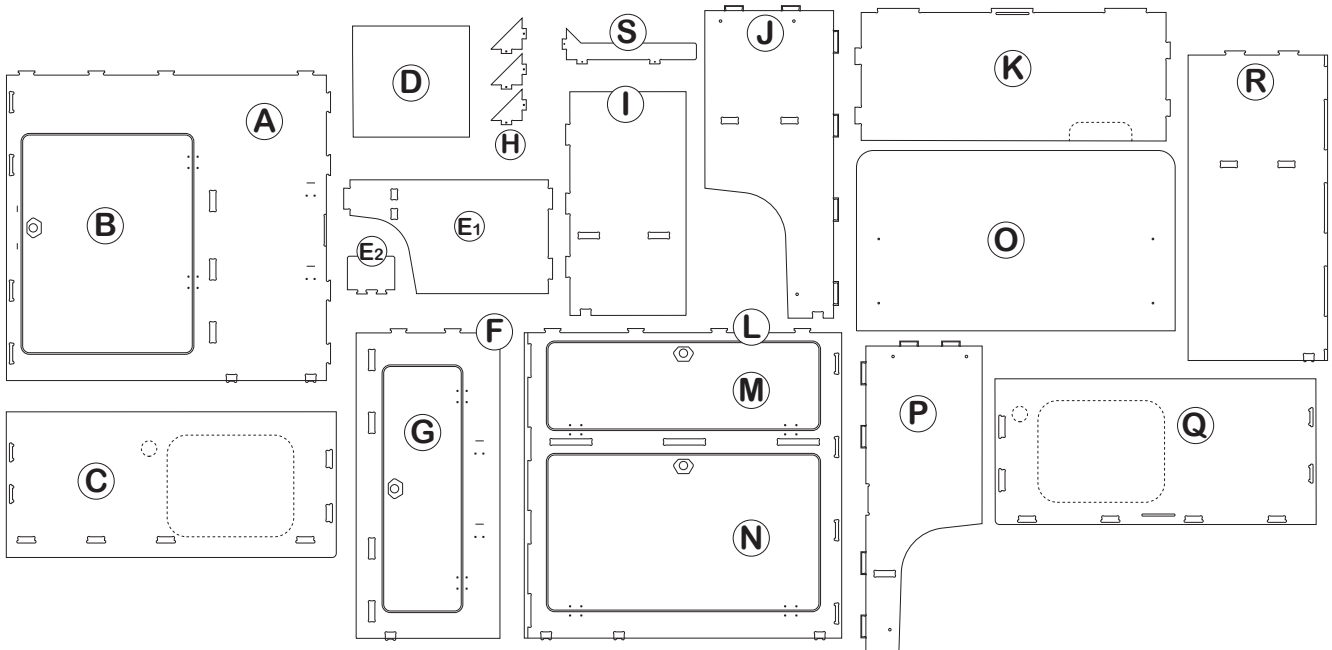
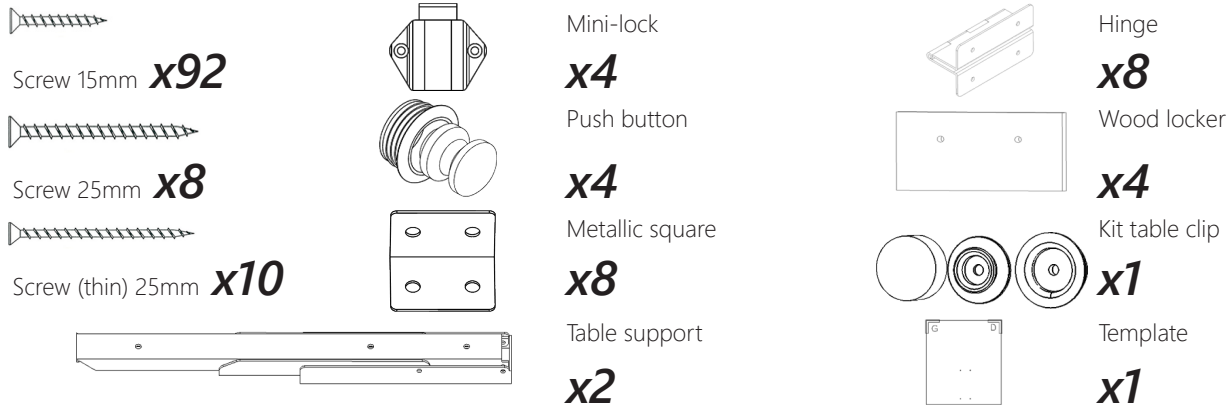

i The parts above are those for the adaptable A3.1 V2 version. Views of the parts for the A3.2 V2, A3.3 V2 and A3.4 V2 versions are available on the next page.

Read before assembling the furniture

- Check for chips in the grooves
- Check that the parts are free of defects before gluing/ or make a dry fitting
- Read the entire instructions carefully before final assembly with glue
- Wipe off excess glue with a damp cloth immediately after gluing each part
- Make any cuts(if necessary) before gluing the furniture
- Protec the surrounding areas of the gluing areas with masking tape to reduce cleaning

If you have a problem with a part or accessory please contact us by email: sav@simplevans.eu

A3.2 V2

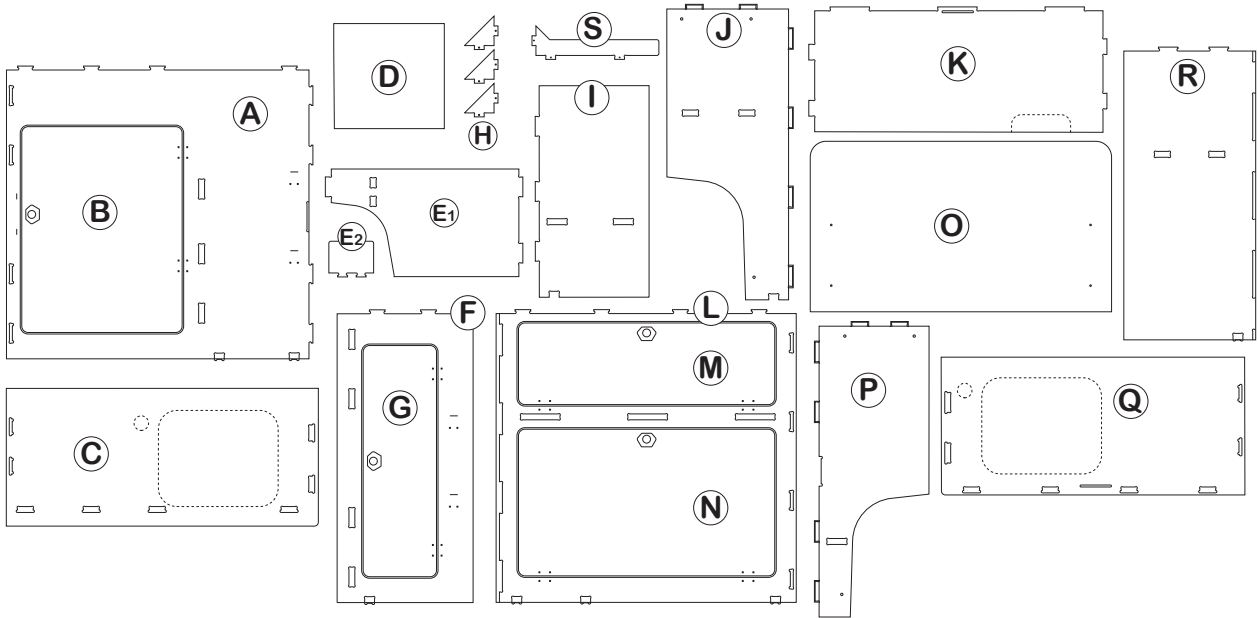

A3.3 V2

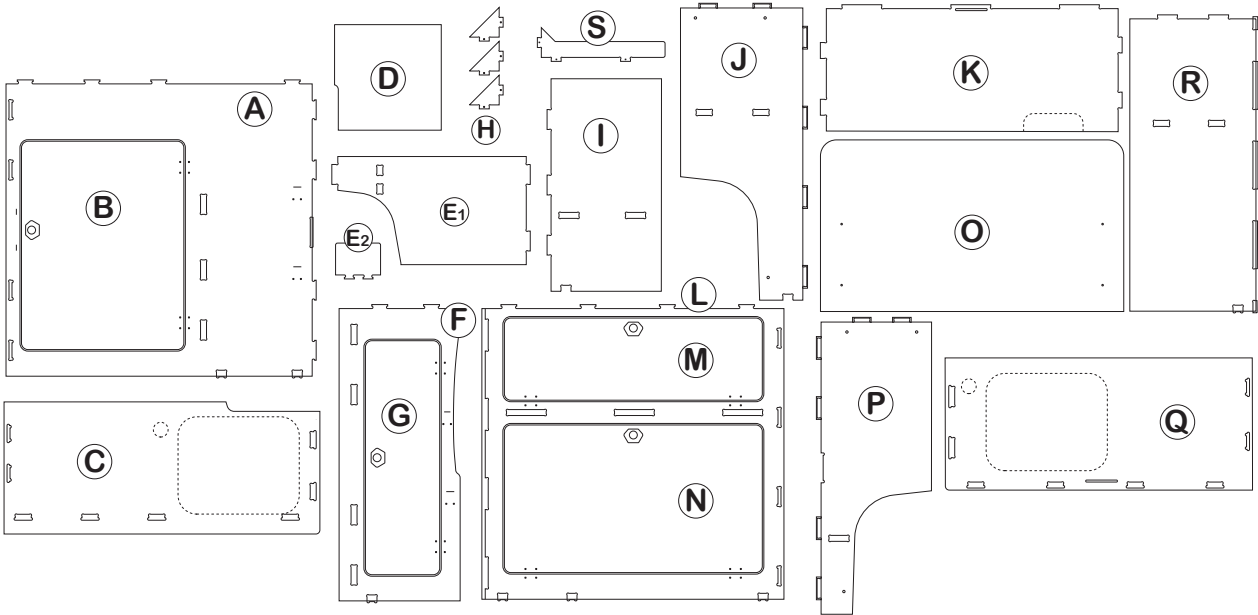

A3.4 V2

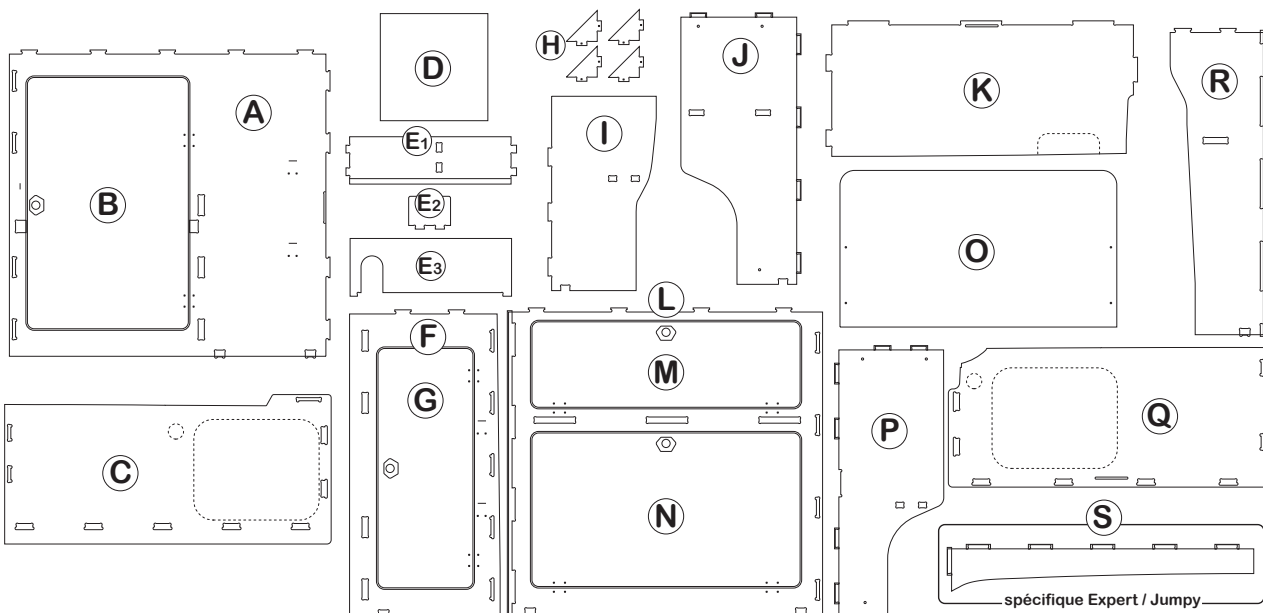



If you do not have a water kit, go to the «Furniture assembly»

These instructions are a **guide for cutting your worktop and shelf to fit the water kit**. To do this, markings have been made on the non-visible sides of the worktops and shelf.

Materials required for cutting:

- Jigsaw and suitable blade
- Drill
- Drill bit diameter matching the size of the jigsaw blade
- Hole saw

REQUIREMENTS FOR CUTTING WITH A JIGSAW



When using a jigsaw, wear safety glasses to avoid splinters and gloves.

1 Choosing the right blade

Blade profil

Curved blade (wood curves)
Narrow, thin teeth, easy to turn

Standard straight blade
Slightly wider

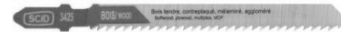
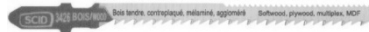

Tooth direction

Teeth facing upwards
Chips on the upper surface

Teeth facing downwards
Chips on the underside

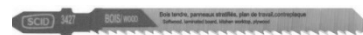
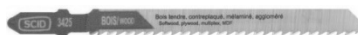

2 Prepare the surface to be cut.

Use the predefined markings on the parts or transfer the templates with a pencil.

Use masking tape along the edge of your cut to reduce the risk of splinters.

3 Cutting **test** on a scrap piece

Use a medium cutting speed

4 Finishing sanding

Ready to cut!

We hope these tips help you!

We are constantly looking to improve, and your feedback will be greatly appreciated!

Let's get back to it!

GUIDE FOR CUTTING

1 Choosing the location of your sink

We recommend that you assemble the unit without glue (follow the furniture assembly instructions) so that you can visualise it and make the choice that suits you best. Any cuts made will be irreversible.

Back sink Option A Concerned parts Q et K

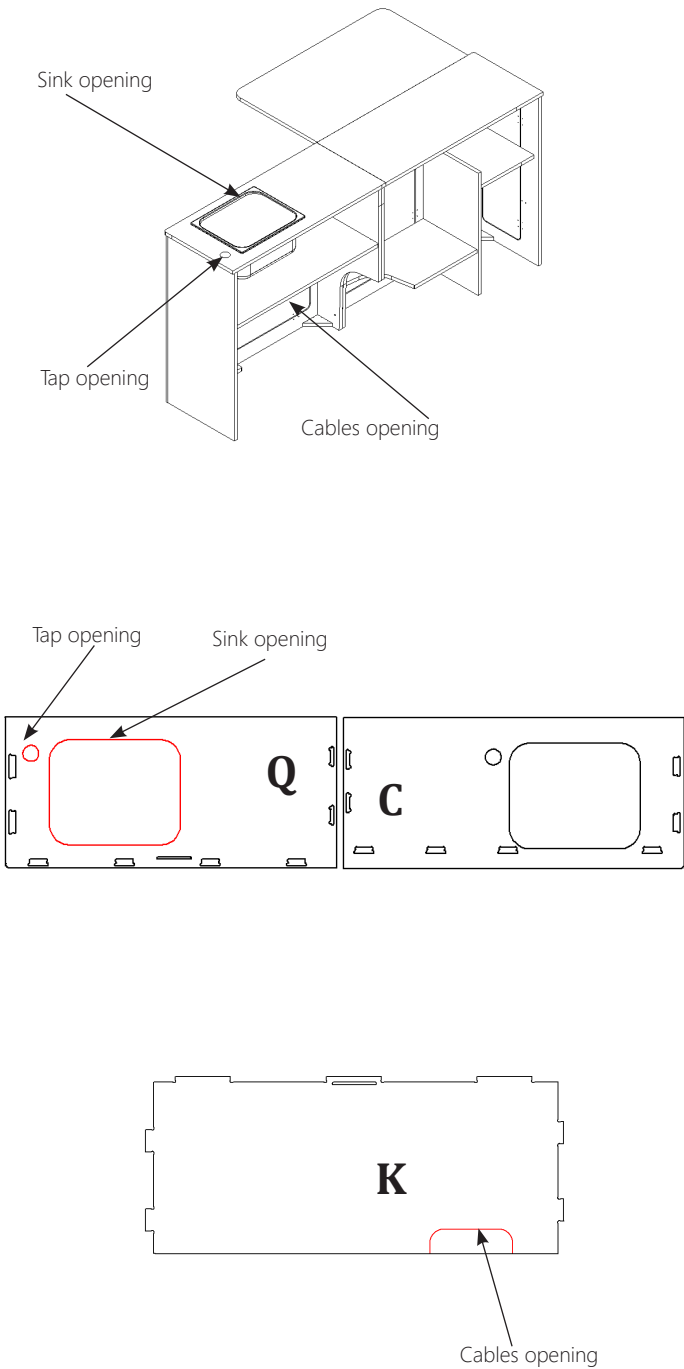

Front sink Option B Concerned part C

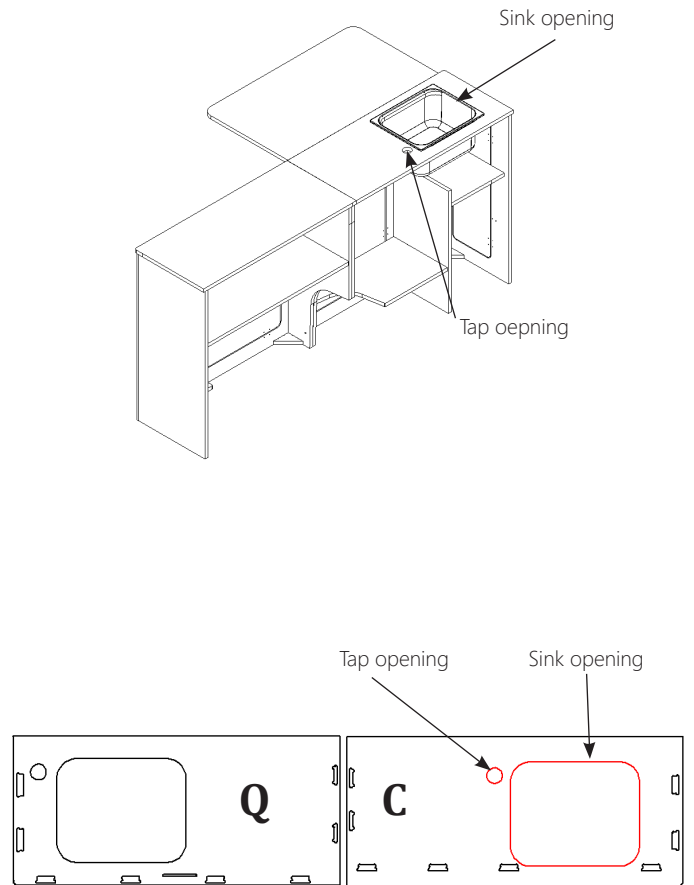

GUIDE FOR CUTTING

- 2 Option A only: Cutting the shelf K.** Use a jigsaw and a cutting blade (preferably a curved blade) with the teeth facing upwards. Follow the marked lines.
- 3 Option A & B : Tap opening.** Cut with a jigsaw following the outline on the non-visible side of the worktop.
- 4 Option A & B: Sink opening:** Cut with a jigsaw following the outline on the non-visible side of the worktop.

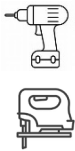

Tip for cutting into your worktop: drill at least one hole in the corner inside the outline (using a drill bit with the same diameter or bigger as your jigsaw blade), then insert your blade into one of the holes and start cutting.

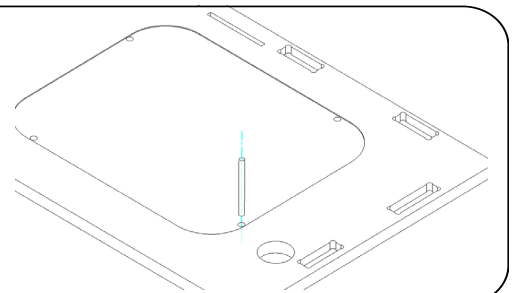

Tuto video available on the website

Well done! You have completed the A3V2 cuts.

We hope you're proud of yourself,

Share your progress and milestones with us!

We are constantly looking to improve, and your feedback will be greatly appreciated!

Let's get back to it!

FRONT UNIT ASSEMBLY



Time estimated: **60min**



Apply **sufficient glue** to the contact surfaces and into the notches. The **glue should protrude** slightly from the notches when assembled. **Wipe off any excess** glue with a damp cloth after assembly.

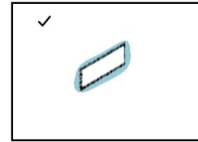
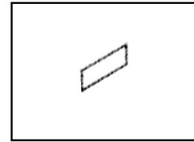
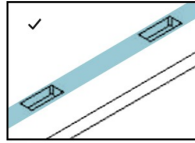
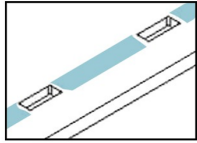

The glue should come out of the joints slightly after assemble, then you know you have the right amount

1 Apply glue to the notches and joints, then assemble the parts **A & I**.

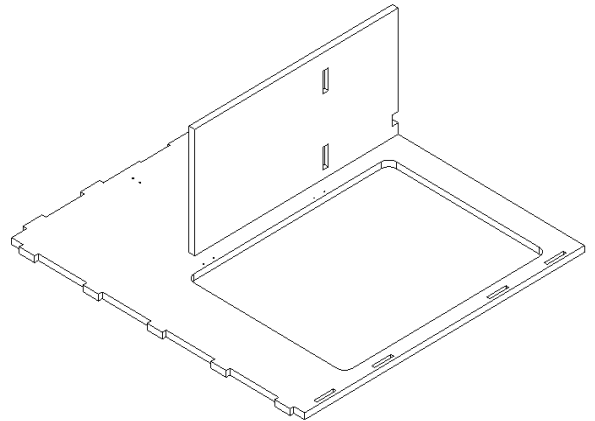
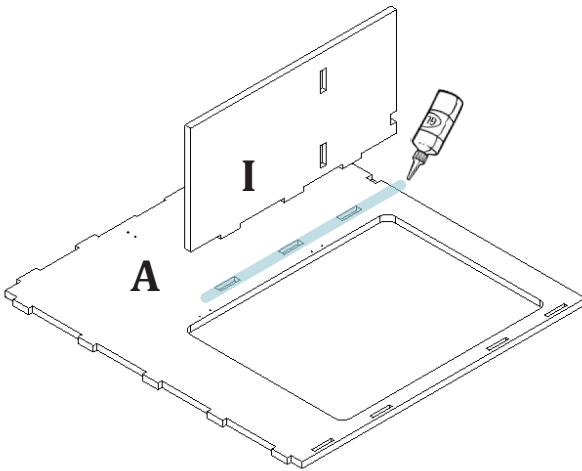

2 Apply glue to the notches on part **A**, then assemble part **H** and fix it using 2 thin 25 mm screws on markers.

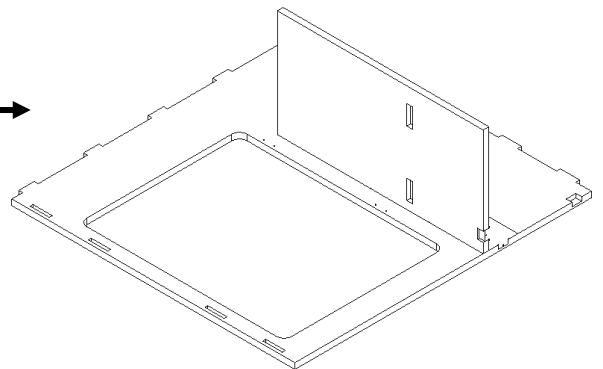
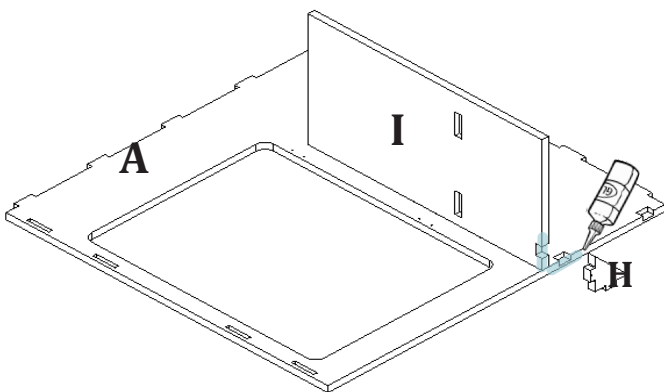

FRONT UNIT ASSEMBLY

3 Apply glue to the notches and joints, then assemble the parts **I** & **E1**.

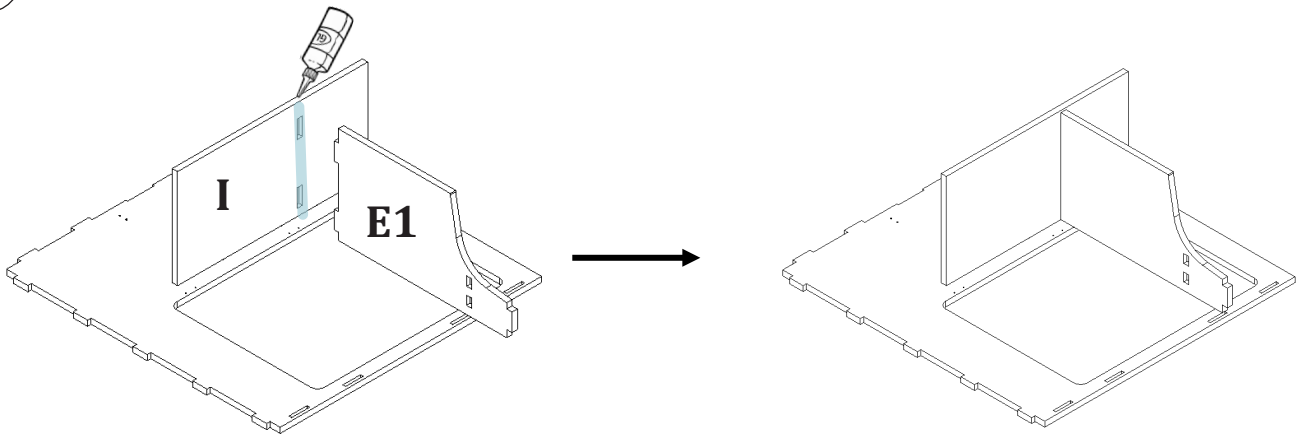

! For version A3.4 V2 : the shelf **E** is in 2 parts: a removable part **E3** and a fixed part **E1** (this allows you to position and remove the water kit if you have selected it), **E2** is a part for securing your water containers

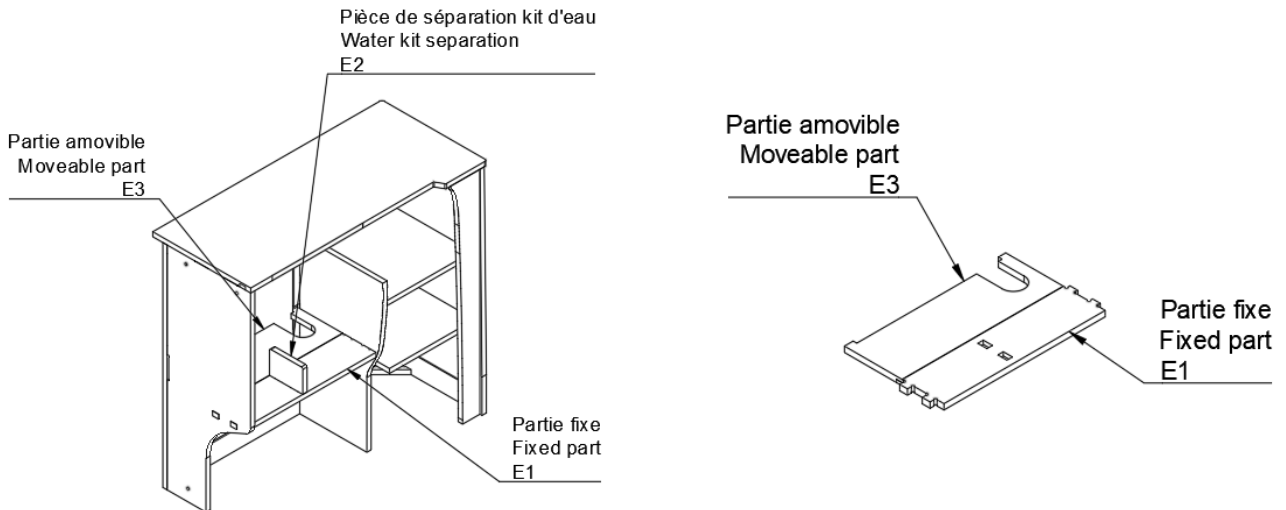

3bis Apply glue to the notches and joints of part **I** and assemble the fixed part of part **E1**. Set parts **E3** and **E2** aside; you can position them once the unit has been assembled.

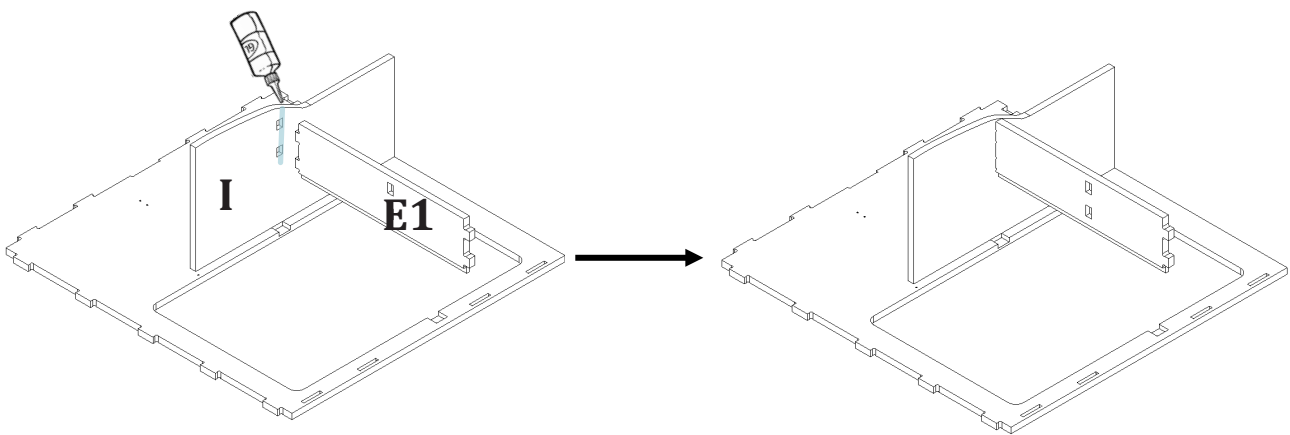

FRONT UNIT ASSEMBLY

- 4 Apply glue to the notches and joints of part **A**, then assemble part **P**.

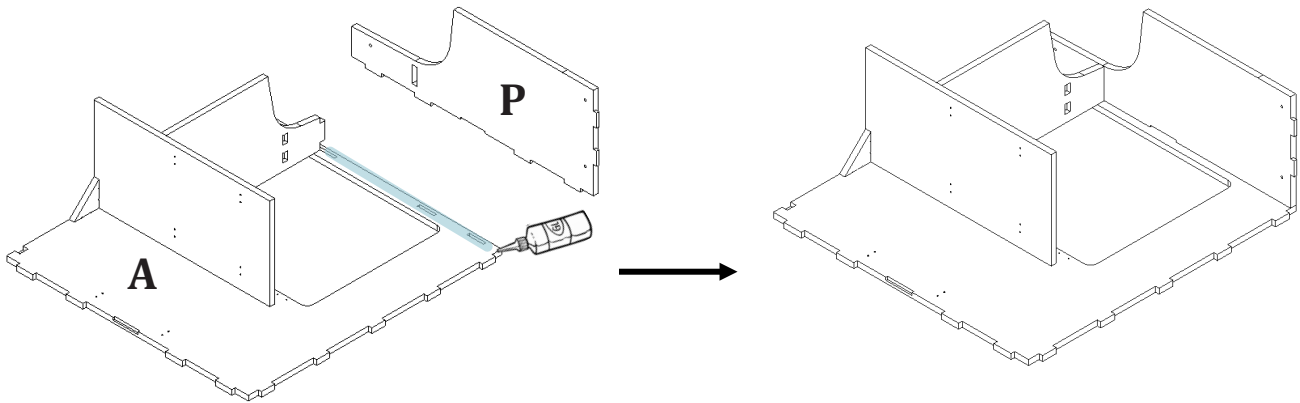

- 5 Apply glue to the notches and then assemble part **F**

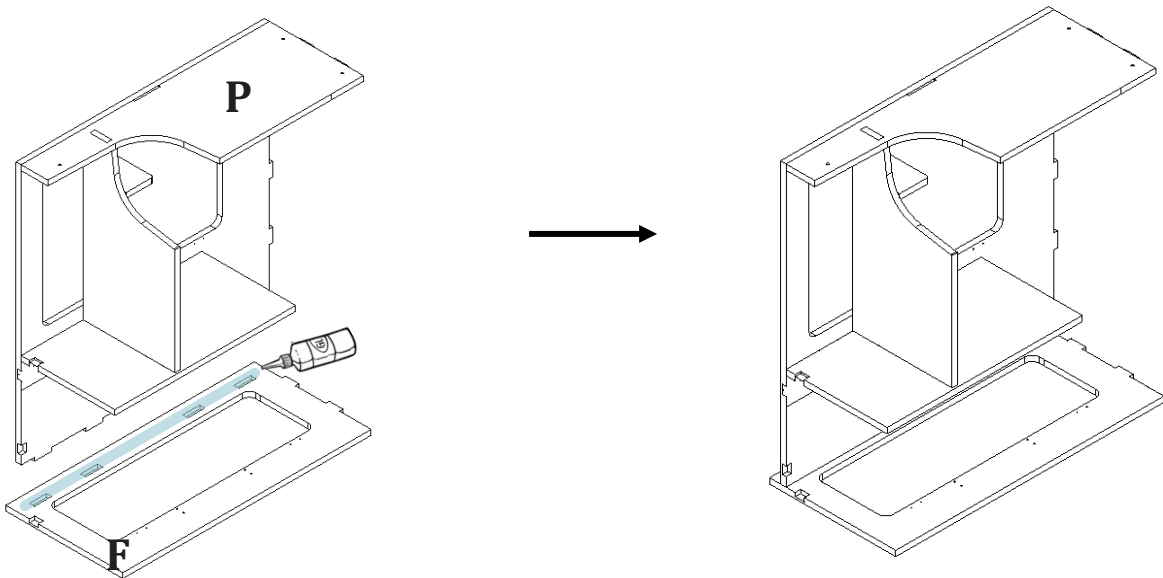

- 6 Apply glue to the notches on part **A**, then assemble one of the **H** parts and secure it using two **25 mm thin screws in the pre-drilled holes**.

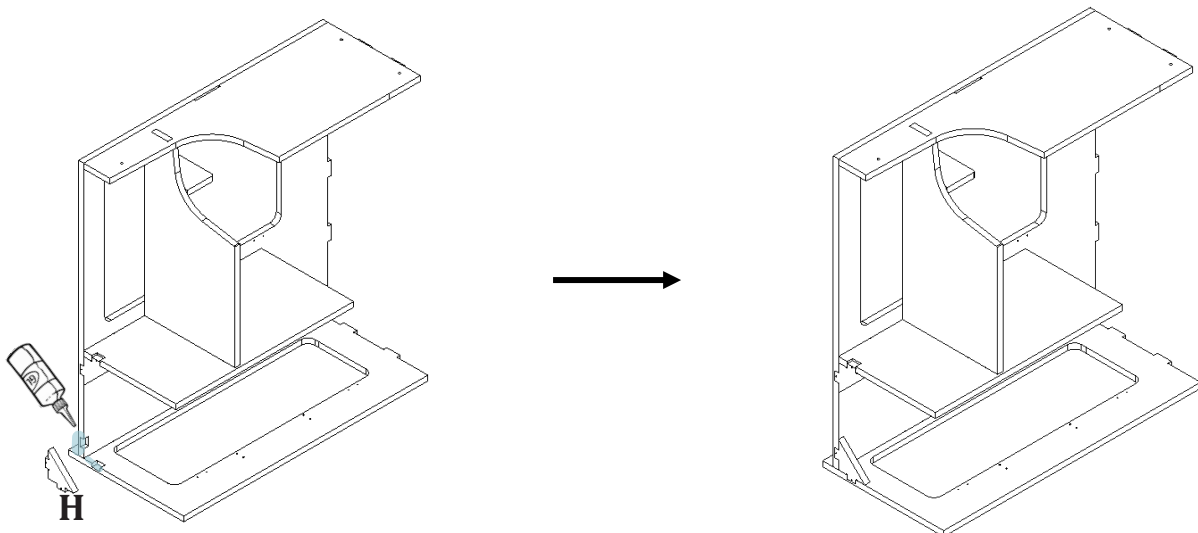

FRONT UNIT ASSEMBLY

6a Only for the A3.4 V2 version: apply glue to the notches and joints and assemble part **S** onto part **F**. For other versions (A3.1 V2/ A3.2 V2/ A3.3 V2), proceed directly to the next step.

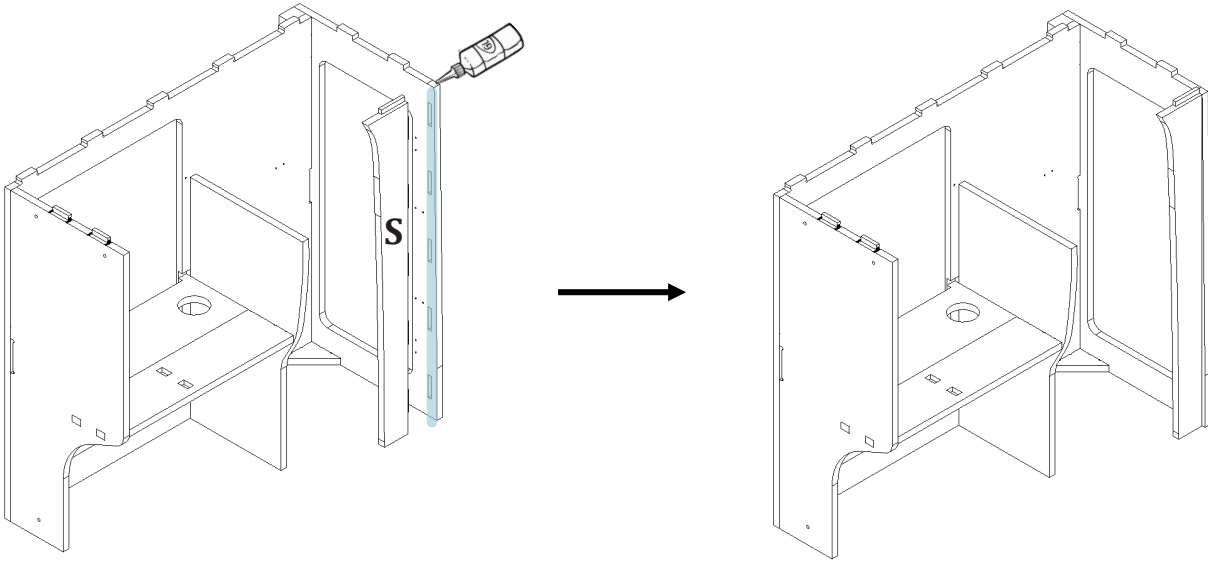

7 Apply glue to the notches and assemble the worktop **C**

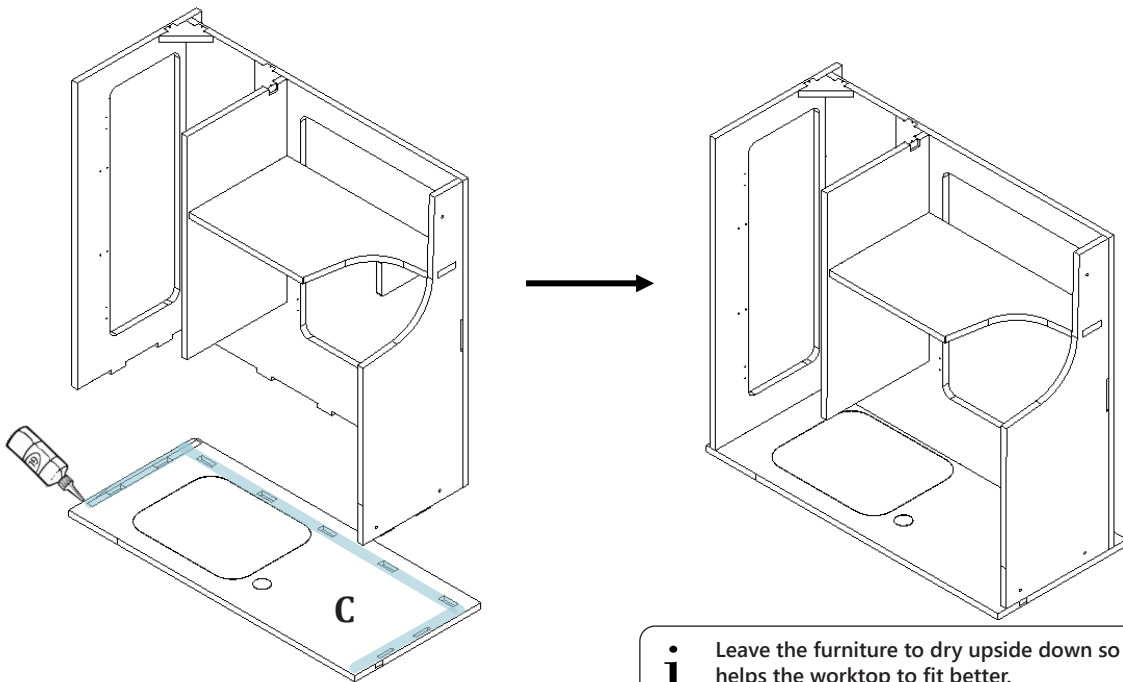

i Leave the furniture to dry upside down so that gravity helps the worktop to fit better.

Well done! You have finished gluing the front unit of A3V2.

Did any step seem difficult or poorly explained?

Share your progress and milestones with us!

We are constantly looking to improve, and your feedback will be greatly appreciated!

Let's get back to it!

BACK UNIT ASSEMBLY



Time estimated: **60min**

- 1** Apply glue to the notches and joints, then assemble the parts **J** and **K**.

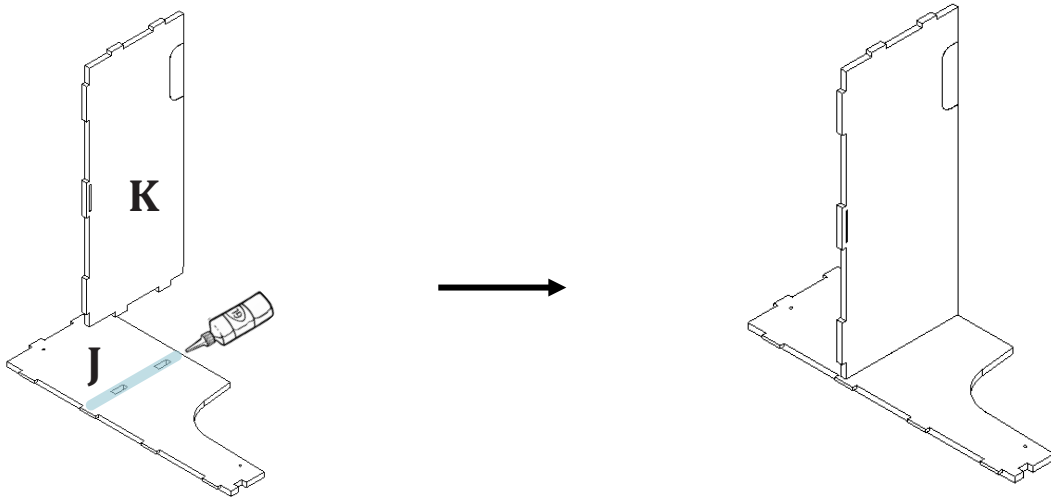

- 2** Apply glue to the notches and joints, then assemble the parts **with part L**.

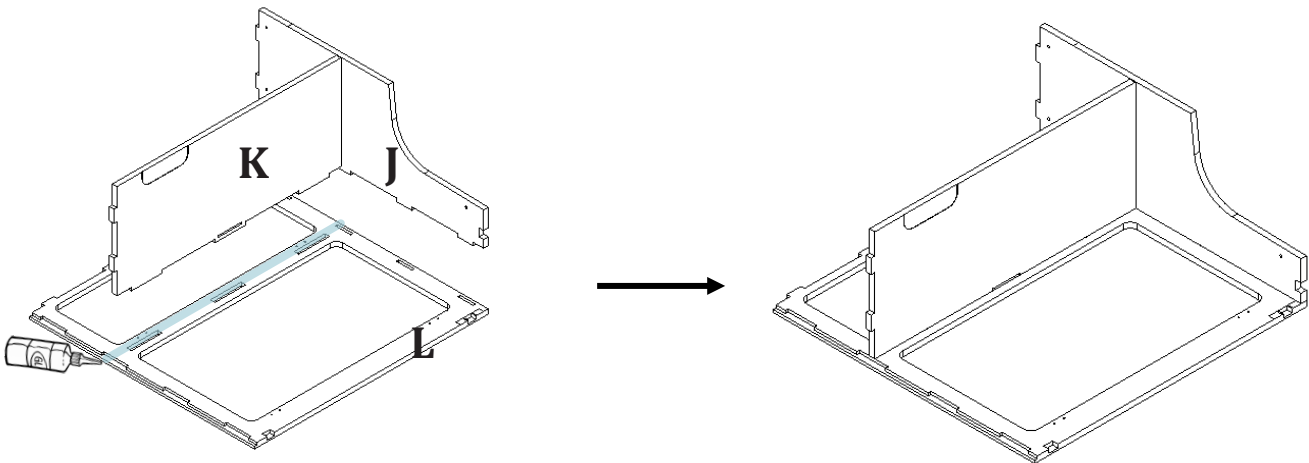

- 3** Apply glue to the notches on part **L**, then assemble one of the **H** parts and fix it using two **25 mm thin screws in the pre-drilled holes**.

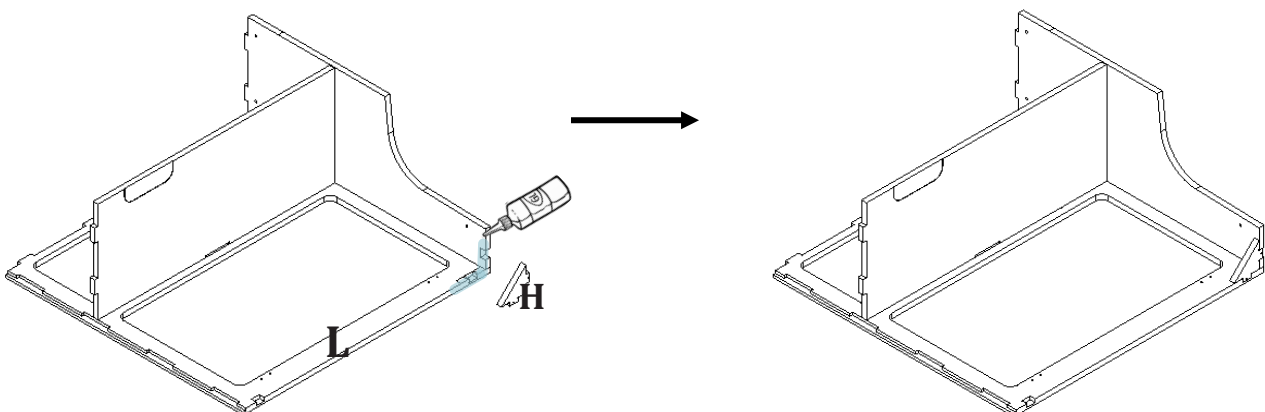

BACK UNIT ASSEMBLY



Time estimated: **60min**

- 4 Apply glue to the notches and joints, then assemble the part **R**

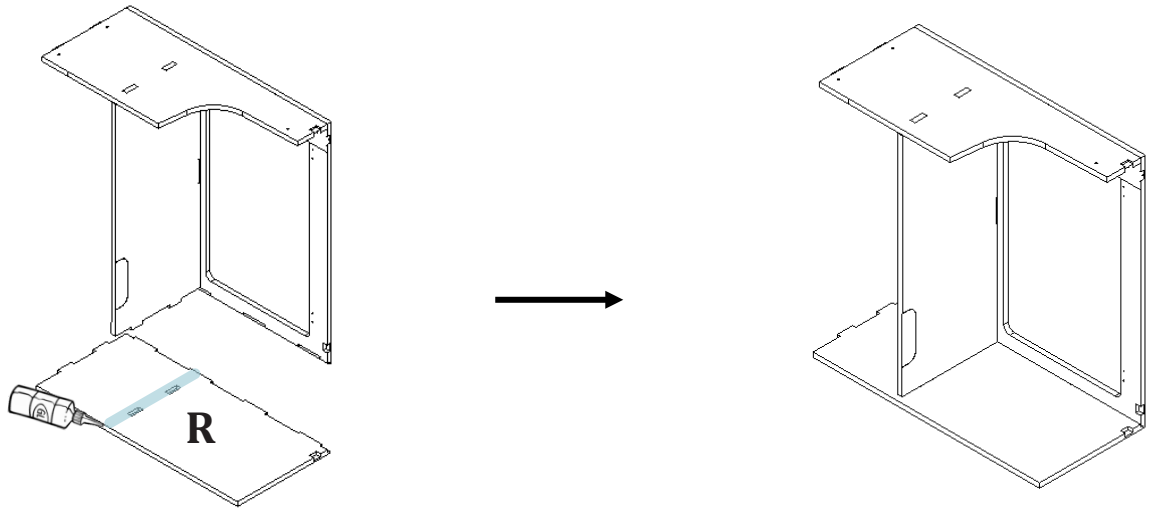

- 5 Apply glue to the notches on part **L**, then assemble **S** part and secure it using three **25 mm thin screws in the pre-drilled holes.**



For version A3.4 V2 : use one of the **H** parts and fix it with **two 25 mm thin screws in the pre-drilled holes.**

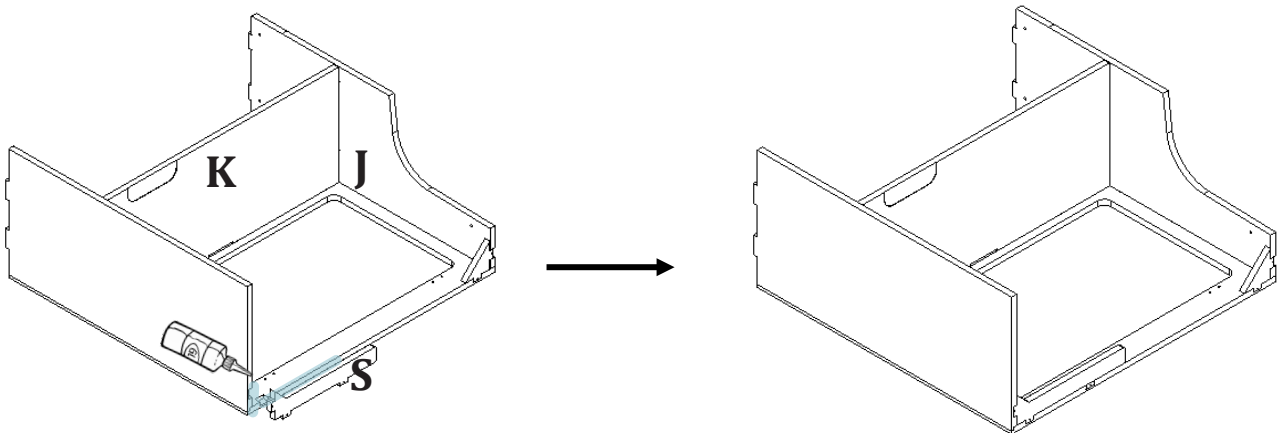

- 6 Apply glue to the notches and assemble the worktop **Q**

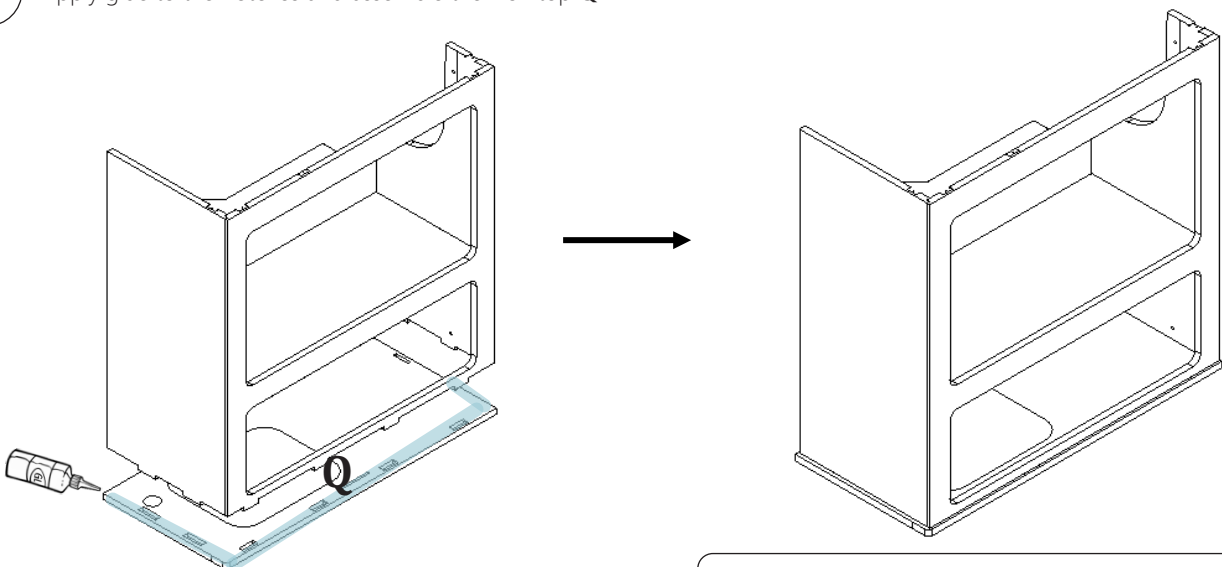

i Leave the furniture to dry upside down so that gravity helps the worktop to fit better.

BACK UNIT ASSEMBLY



Time estimated: **60min**

7

You can now complete the assembly by placing your two blocks next to each other and, if desired, adding the E2 divider to the shelf. The E2 piece can be glued in place or left removable.

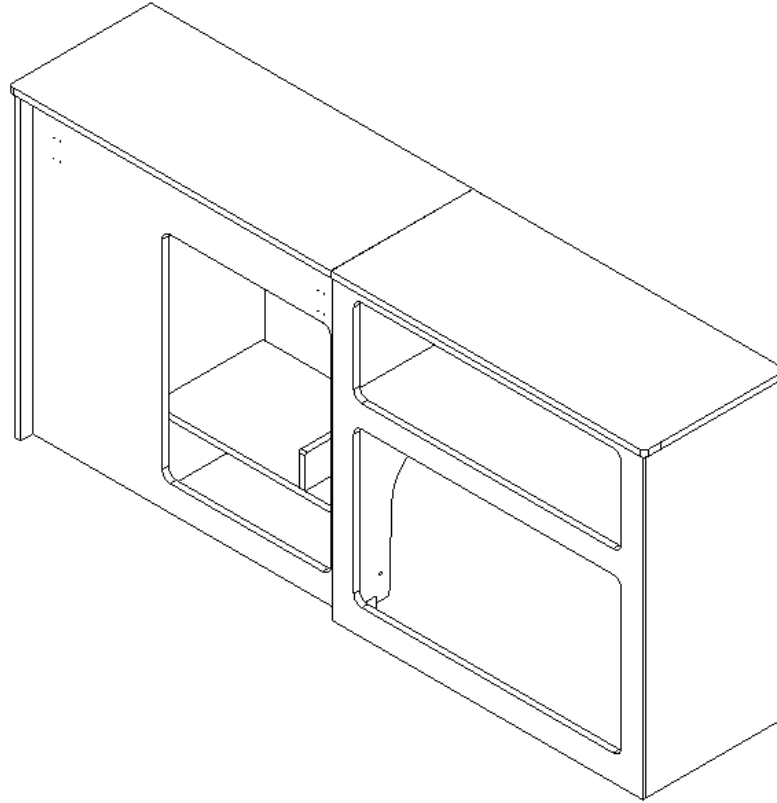

Well done! You have finished the gluing of A3V2.

Did any step seem difficult or poorly explained?

Share your progress and milestones with us!

We are constantly looking to improve, and your feedback will be greatly appreciated!

Let's get back to it!



1 Pushlock assembly



If you want to varnish oil or paint your furniture, it should be done before the following instructions to avoid any paint on the metal and plastics fittings

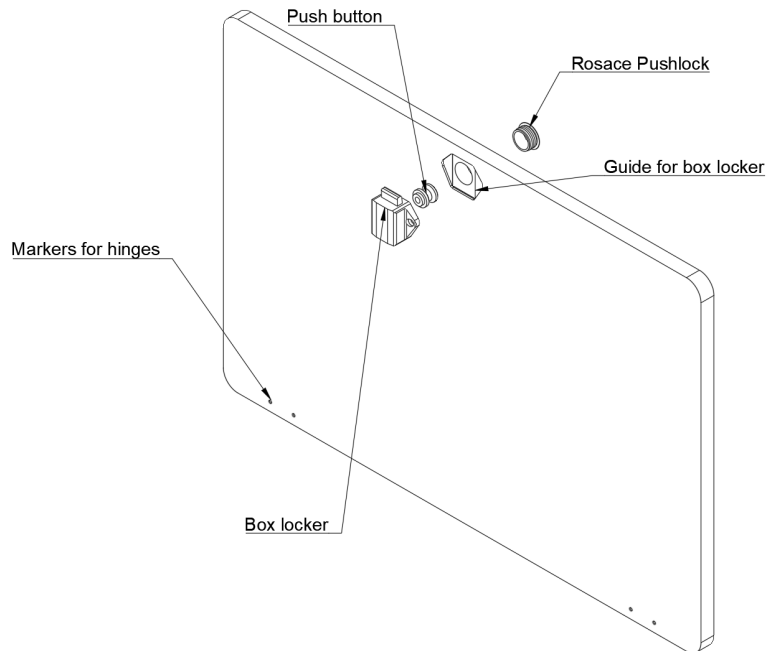

1.1 Force fit the 'push lock rosace' onto the visible side of doors

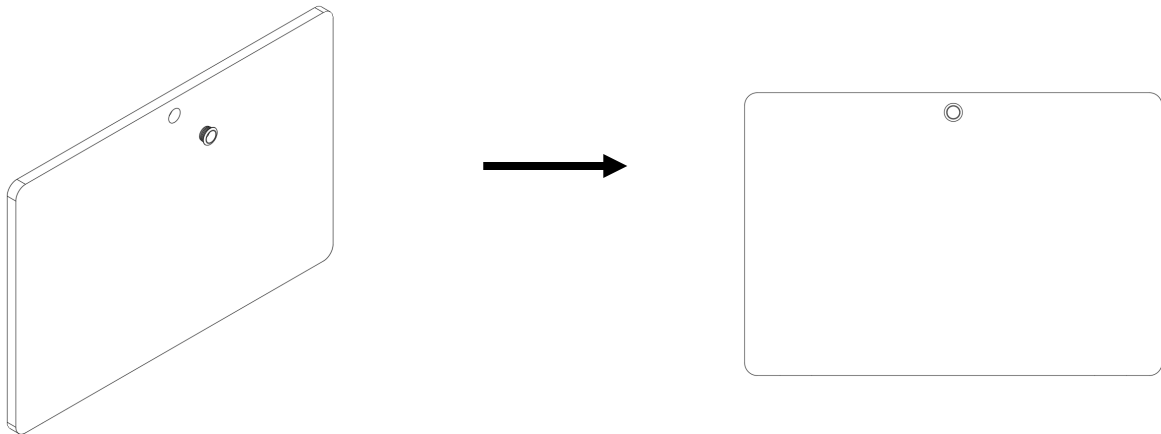

1.2 Screw the 3 push buttons onto each box locker

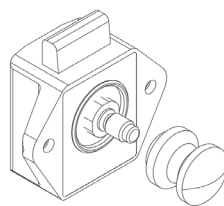

DOORS ASSEMBLY

1.3

Insert the box locker and push button assembly into the guide provided, then screw it in place using 2 x 15 mm screws.
Repeat this process for each door.

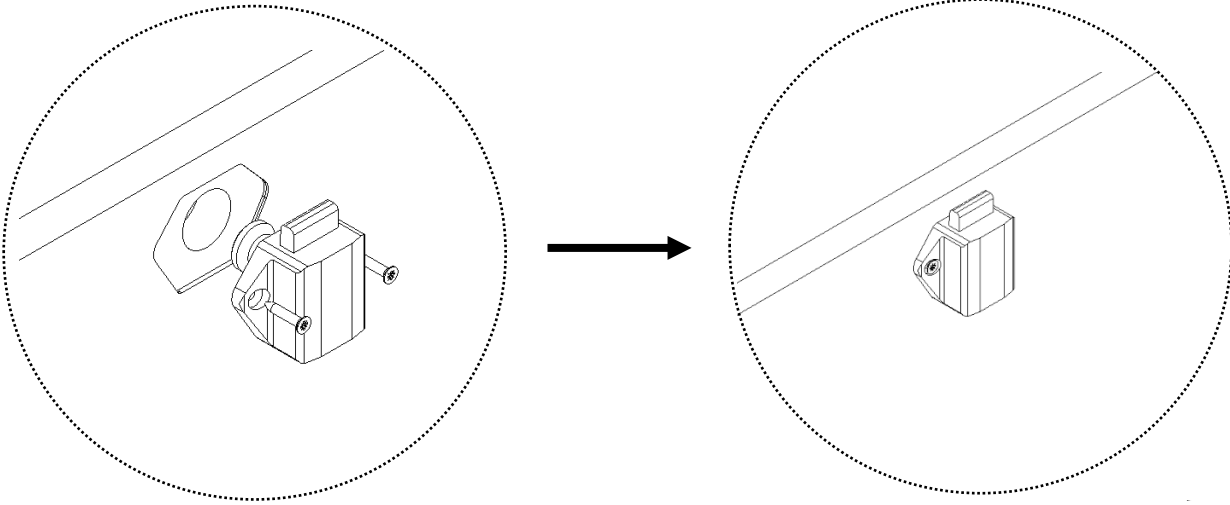

1.4

For areas 1, 2 and 4: Insert the wooden latch into the recess provided and screw it in place using two 15 mm screws.
For area 3: Insert the latch until the holes line up with the marked outline, then screw it in place using two 15 mm screws.

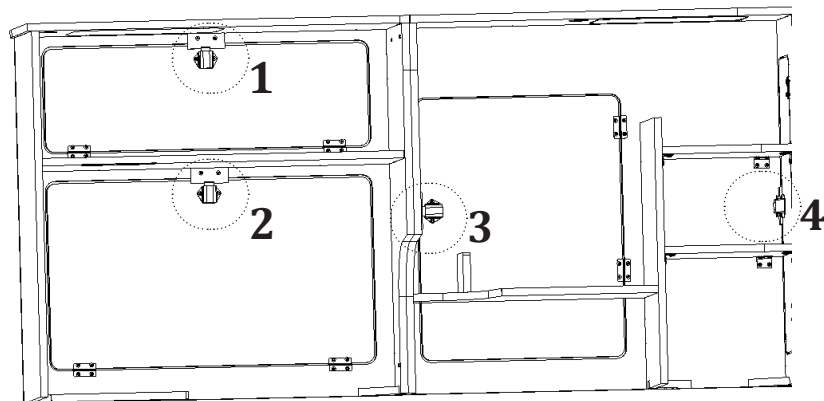
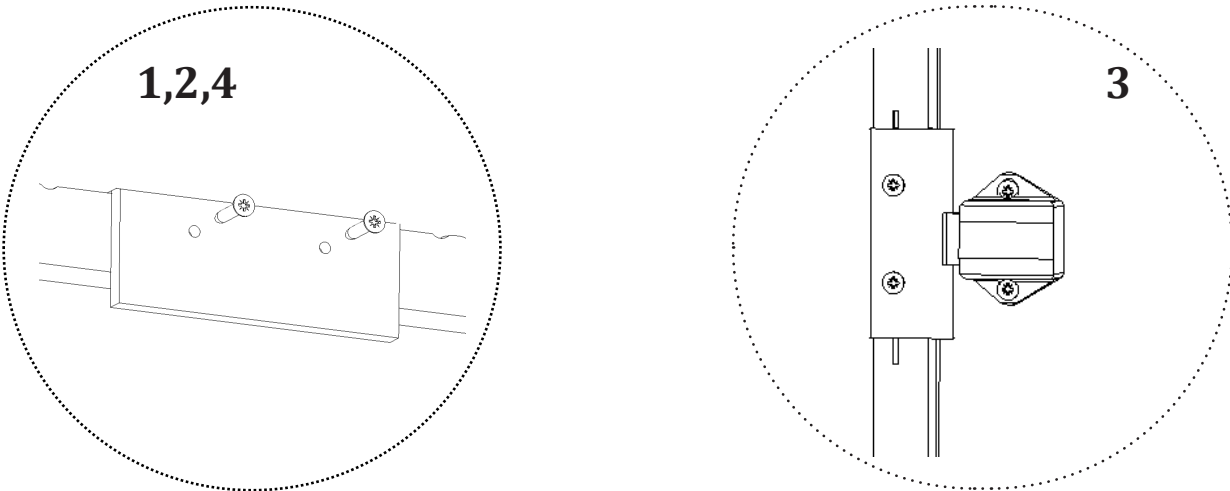

DOORS ASSEMBLY

2 Hinges assembly

i For each hinge, 4 pre-drilled holes are marked on the doors and on the fronts of the furniture.

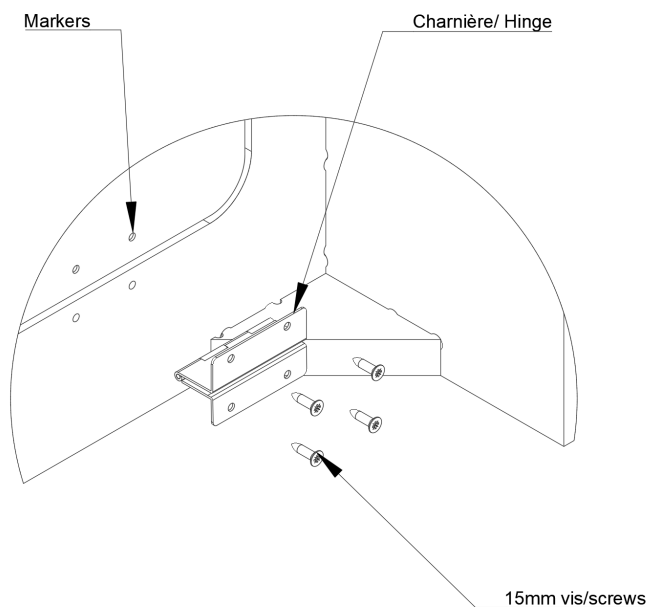

2.1 Screw the hinges onto the doors and then onto the furniture **using the markers/pre-drilled holes** and 15 mm screws. Repeat the process for each door.

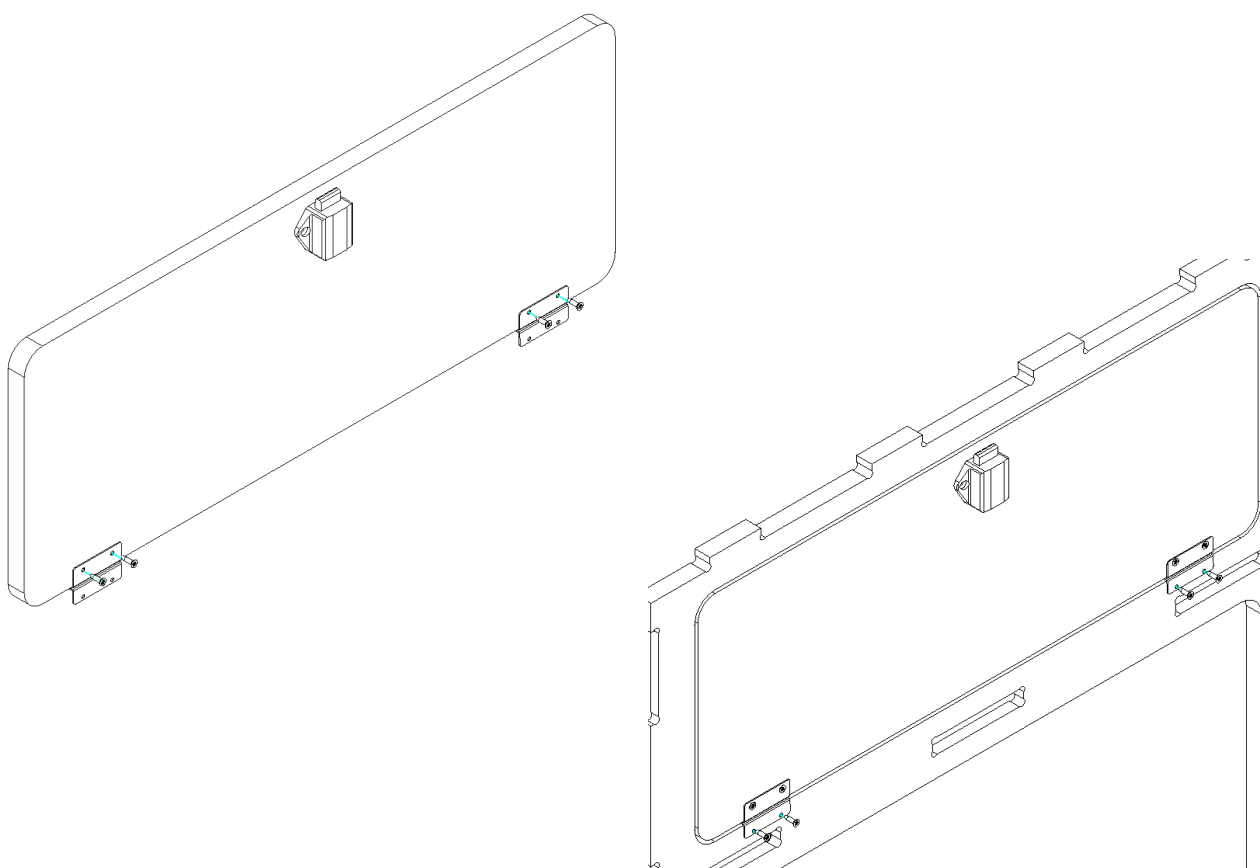

SHELF ASSEMBLY



Time estimated: 15min

- i** The shelf **D** can be fixed at different heights.
The unit have pre-drilled holes to guide the fixing of the metal brackets.

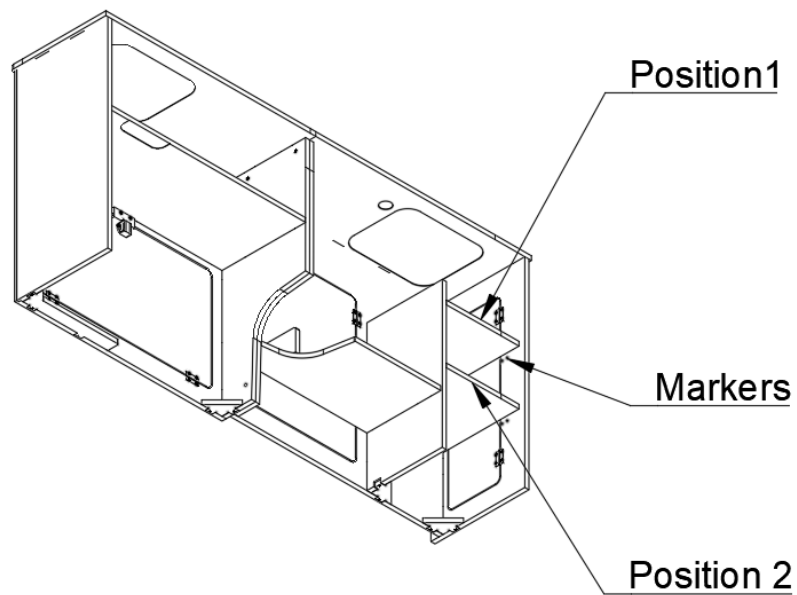

- 1** Screw the metal brackets at the selected height using the **markers/pre-drilled** holes

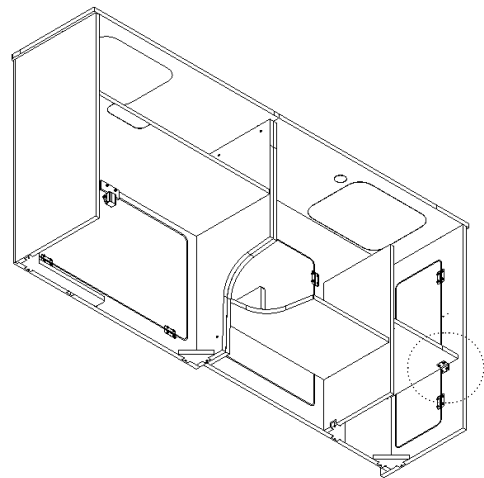
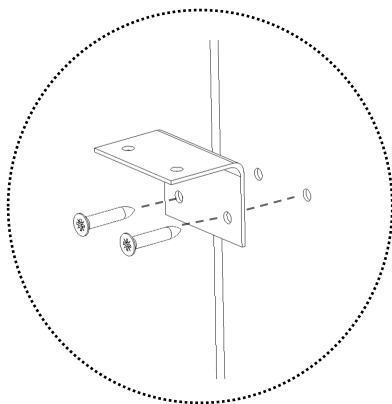

- 2** Place the shelf **D** on the brackets and screw it in place using **15 mm screws**.

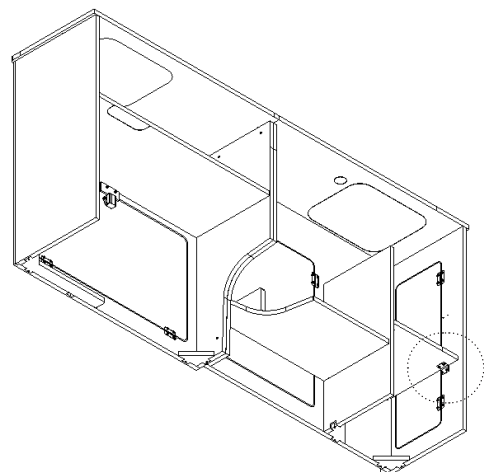
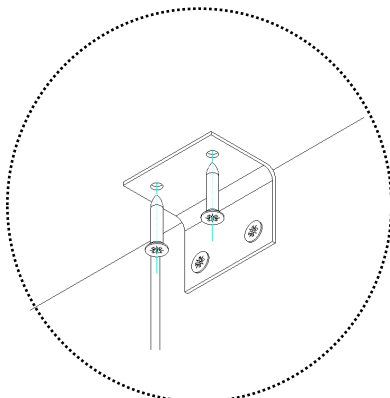



1 Table support assembly

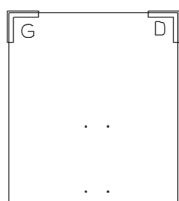

i A wooden template is available to guide you in assembling the table supports.
For version A3.4 V2, the template is narrower, but the assembly principle is exactly the same.

- 1.1** Position corner **G** of the template in the **left-hand corner** of the furniture and **mark the 4 holes** with a screw.
Position corner **D** of the template in the **right-hand corner** of the furniture and **mark the 4 holes** with a screw.

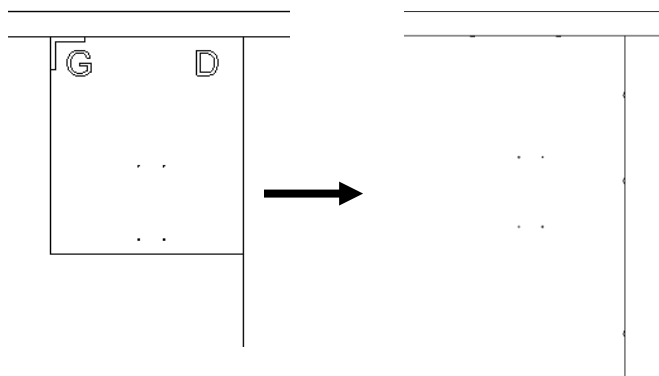
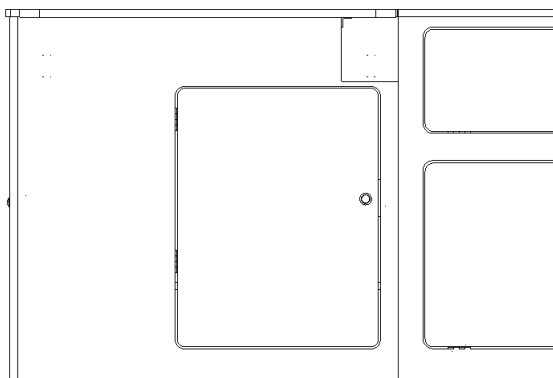
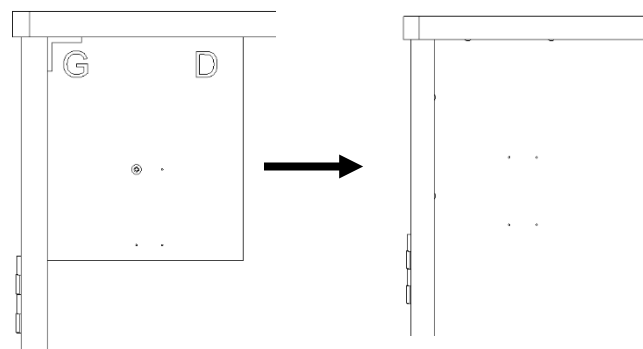
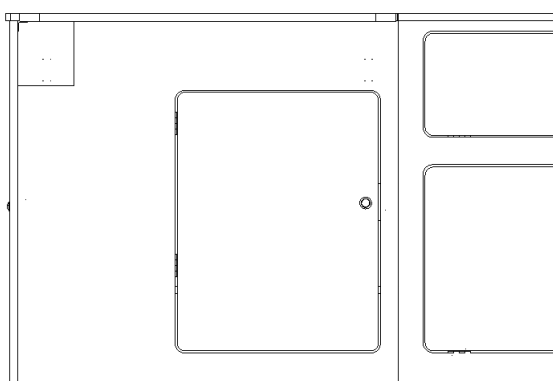

- 1.2** Screw each table support into place **at the points marked** with the template, **using 15 mm screws**.

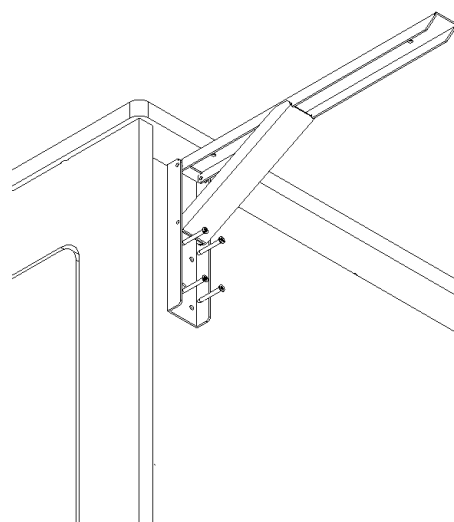
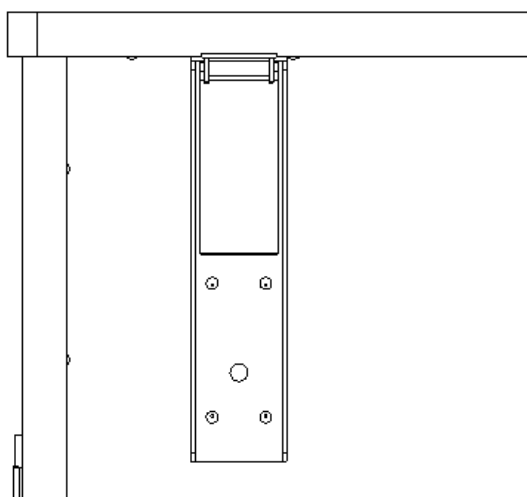
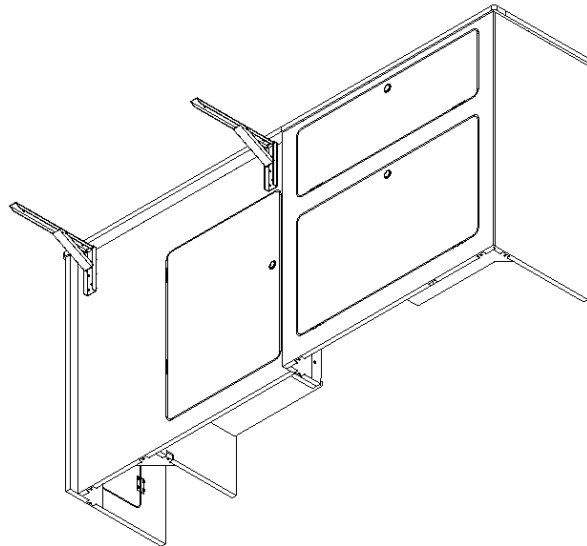
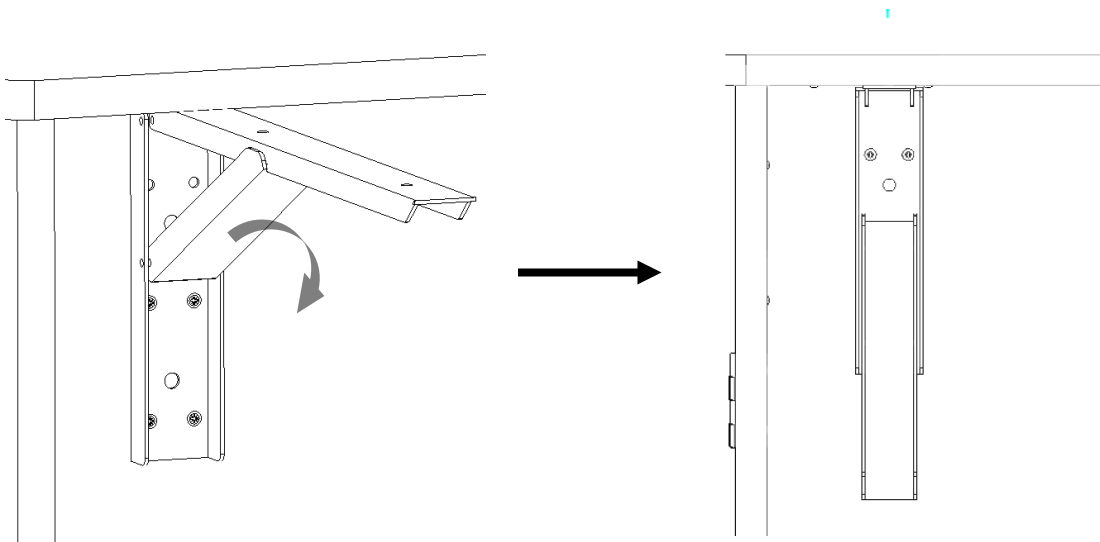

TABLE ASSEMBLY

1.3 Lower the table lock and then add 2x 15 mm screws per table support.



1.4 Position the table on the supports, then align the holes in the table supports with the pre-marked holes on the table. This will ensure proper alignment.

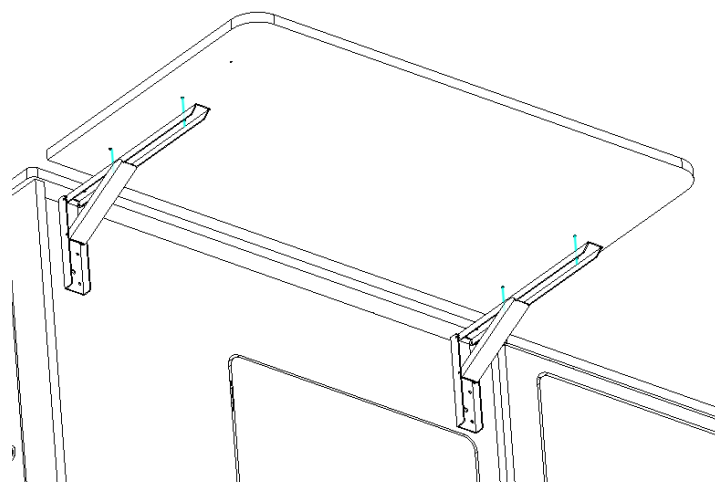

TABLE ASSEMBLY

1.5 Screw with 15 mm screws

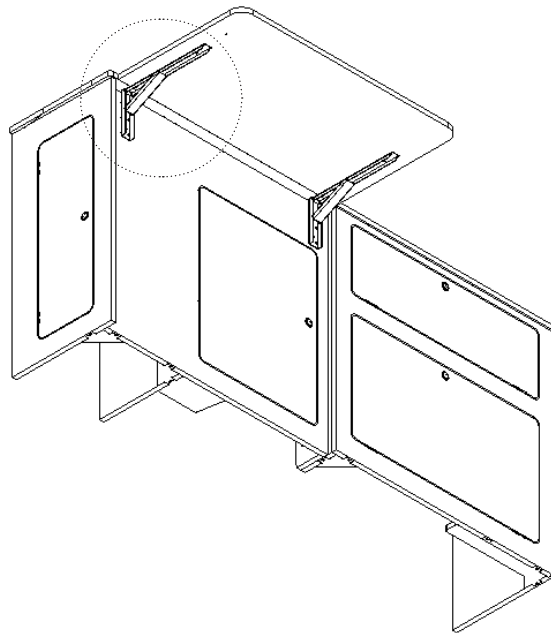
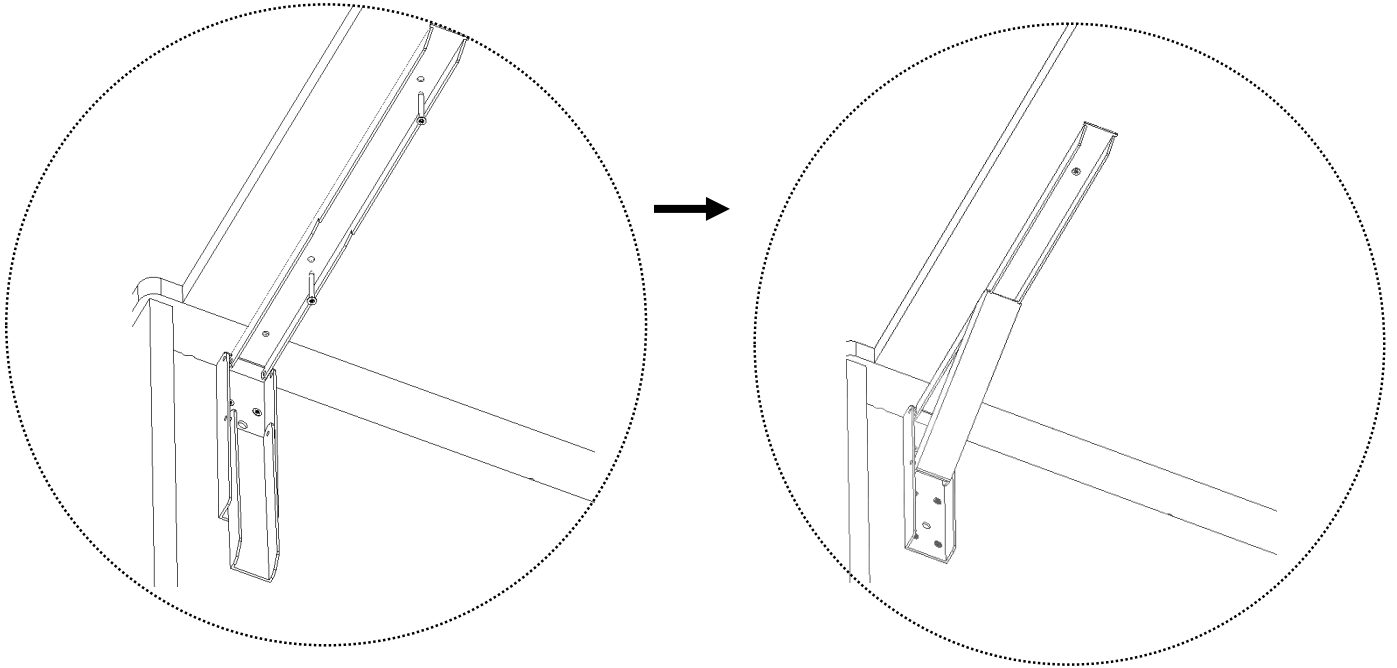
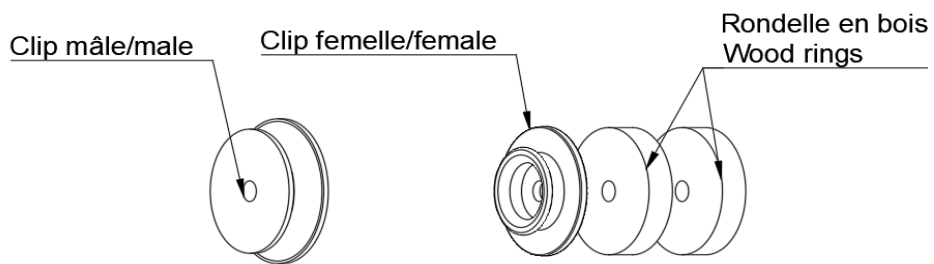
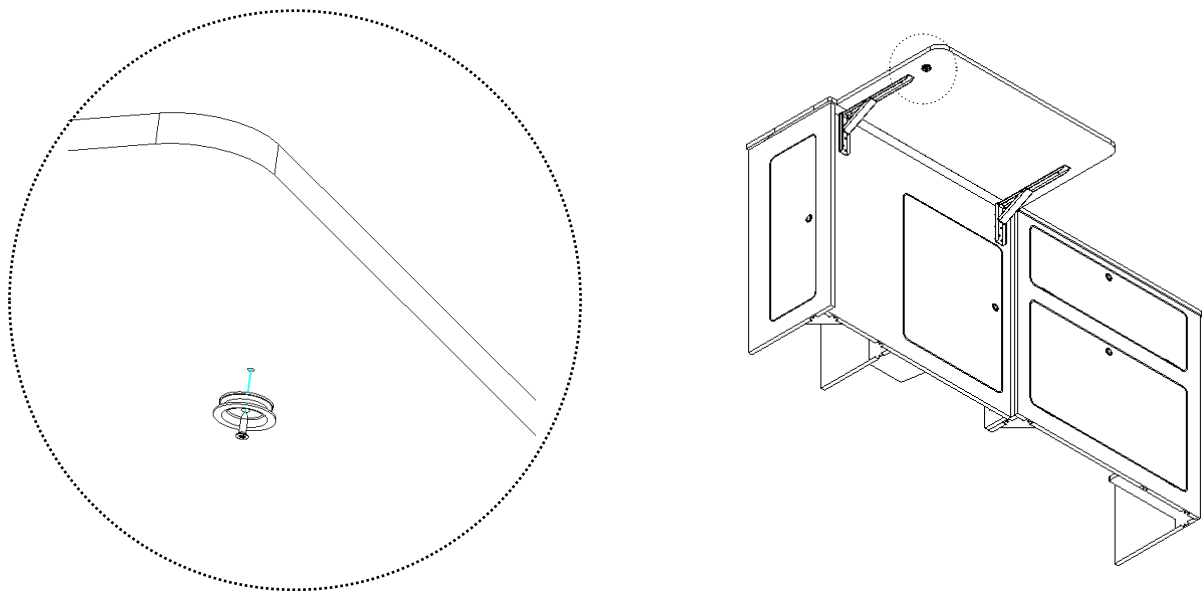

TABLE ASSEMBLY

2 Table clip assembly



2.1 Screw the male clip using 15 mm screws in the pre-drilled hole in the table.



2.2 Screw the 2 wooden discs onto the female clip using the 25 mm screw.

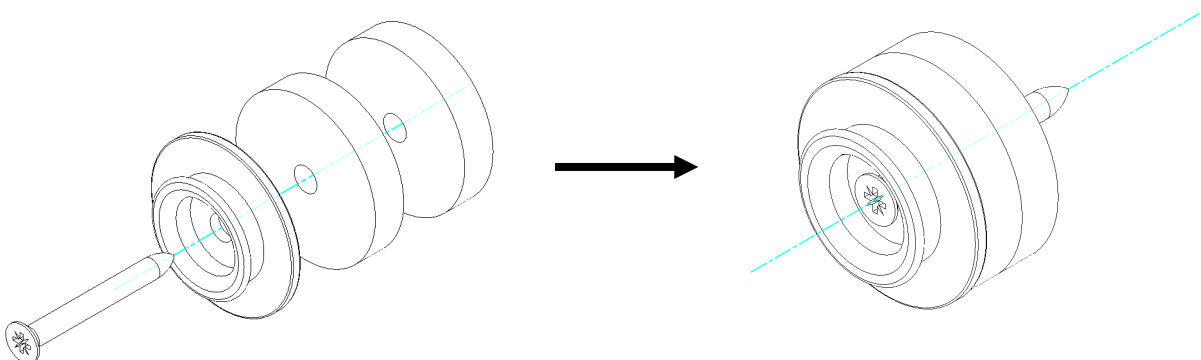
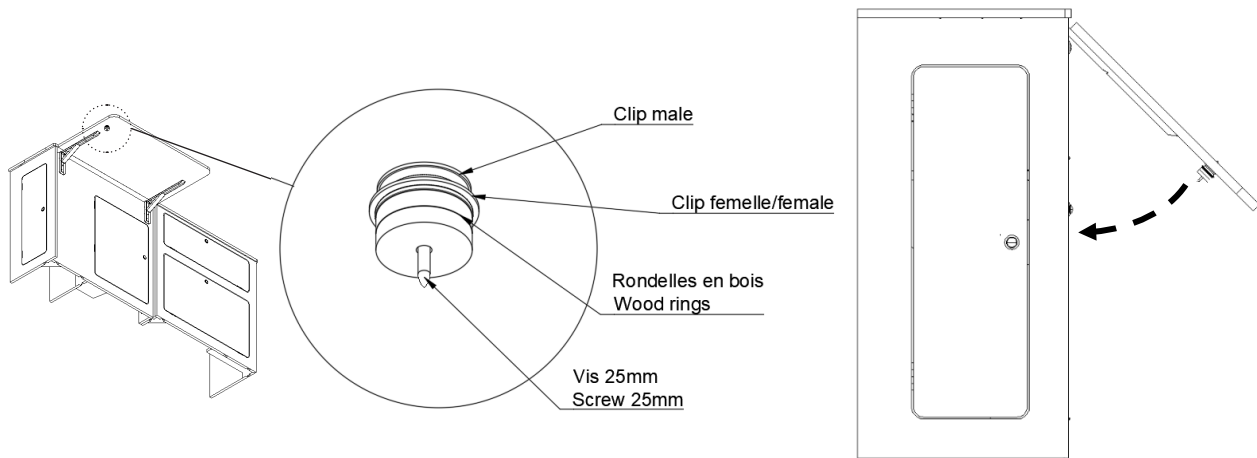

TABLE ASSEMBLY

2.3

Clip the female part and wooden ring onto the male part.
Fold down the table to mark the position on the furniture.



2.4

Unclip the female assembly and fix it to the location marked previously with 25mm screw

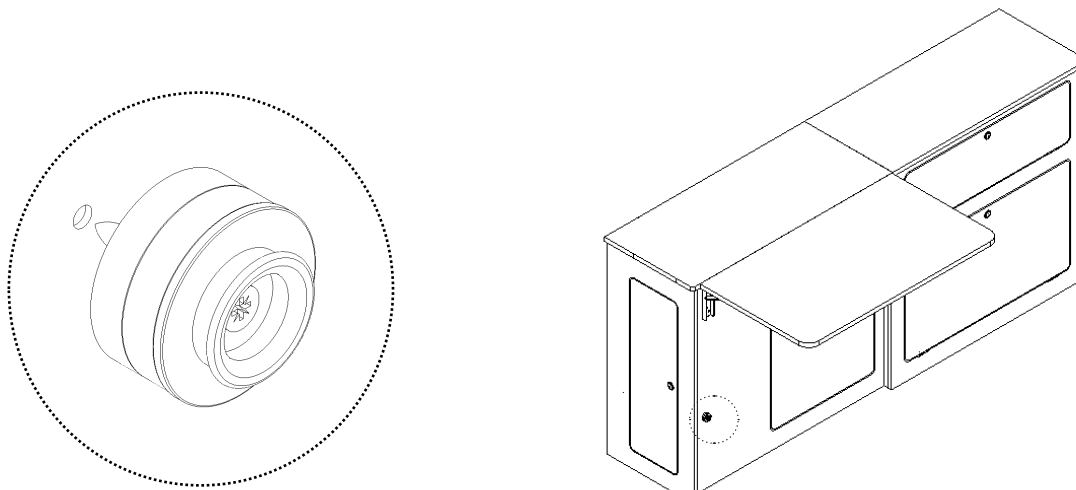

2.5

Make sure that the table clips into place by folding it down firmly.

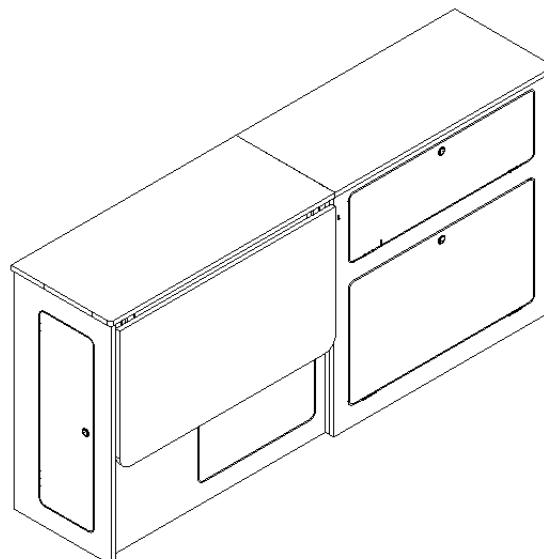

FIXING IN THE VEHICLE



Time estimated: 15min

- 1** Install the unit and validate the fitting, if you have the **adaptable** version you might have to do some **cutting** of the worktop. If you have the others versions A3.2 V2, A3.3 V2, A3.4 V2, the unit should fit in the following vehicles T5/T6, TRAFIC, and JUMPY/EXPERT.
- 2** Fix the remaining squares using **15mm screws on the worktops**, at least 2 at the extremities and one in the middle, **face 1** of the square should be **aligned** with **face 2** of the worktop

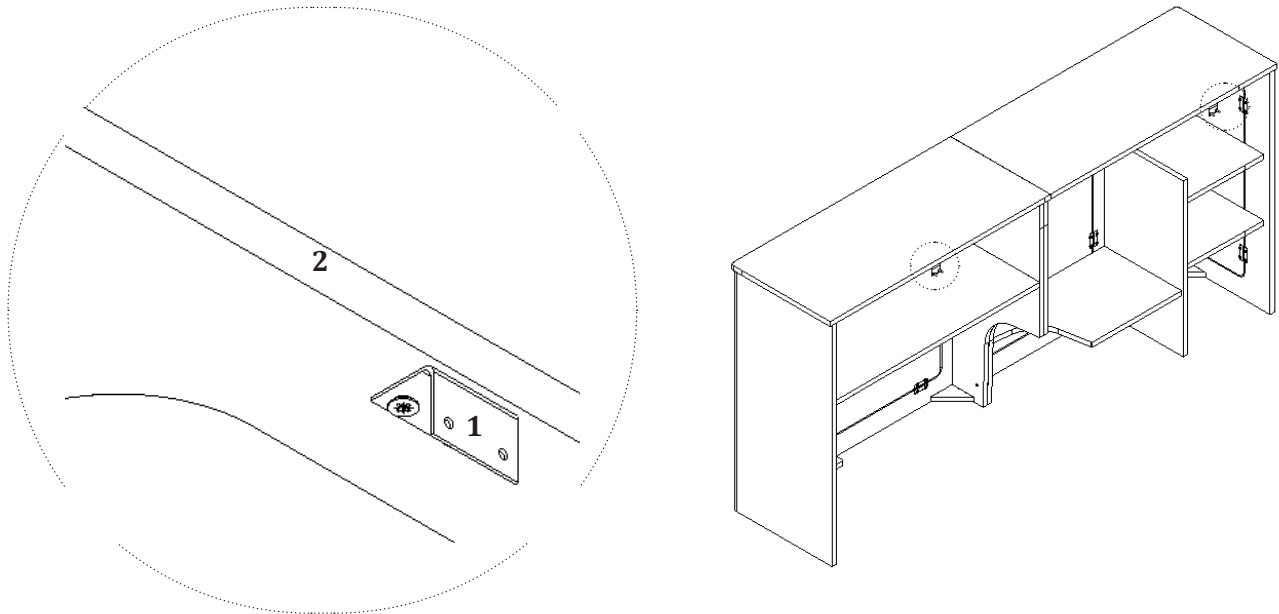

- 3** Put the unit in the final position and fix it to the floor using the **25 mm wide screws**.

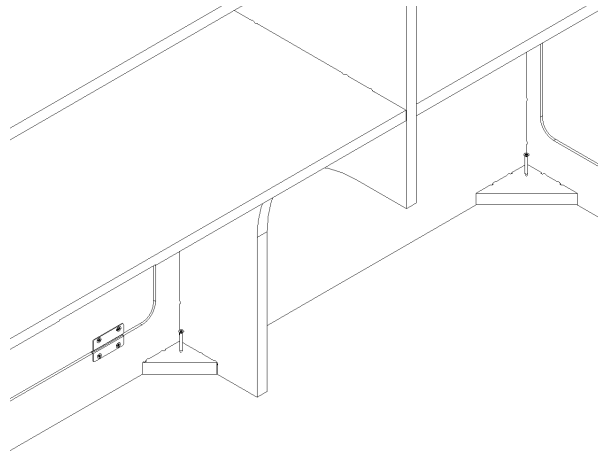

- 4** Fix the **squares** to your wood covering with **15mm screws**

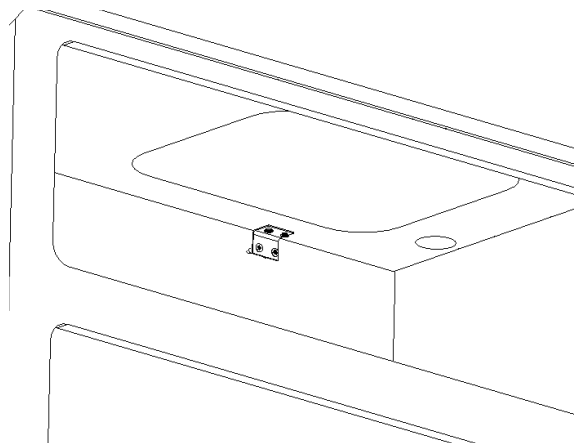

HAPPY ASSEMBLY!

If you have any comments regarding the assembly, you can let us know by email

sav@simplevans.eu

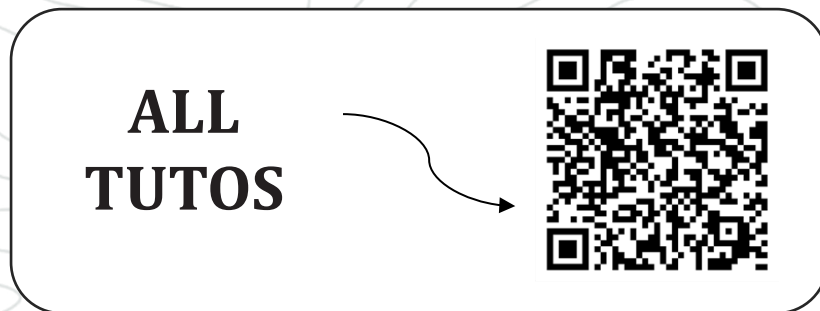

SHARE YOUR EPIC VAN BUILD JOURNEY WITH US AND THE COMMUNITY!

#SimpleVanslife

Snap some pics or record a video of your awesome furniture installed and ready for adventure.

We'll feature the best content on our social media channels, and the most inspiring builds will win incredible prizes!

